

REV	DESCRIPTION	DATE	CHGD	CHKD

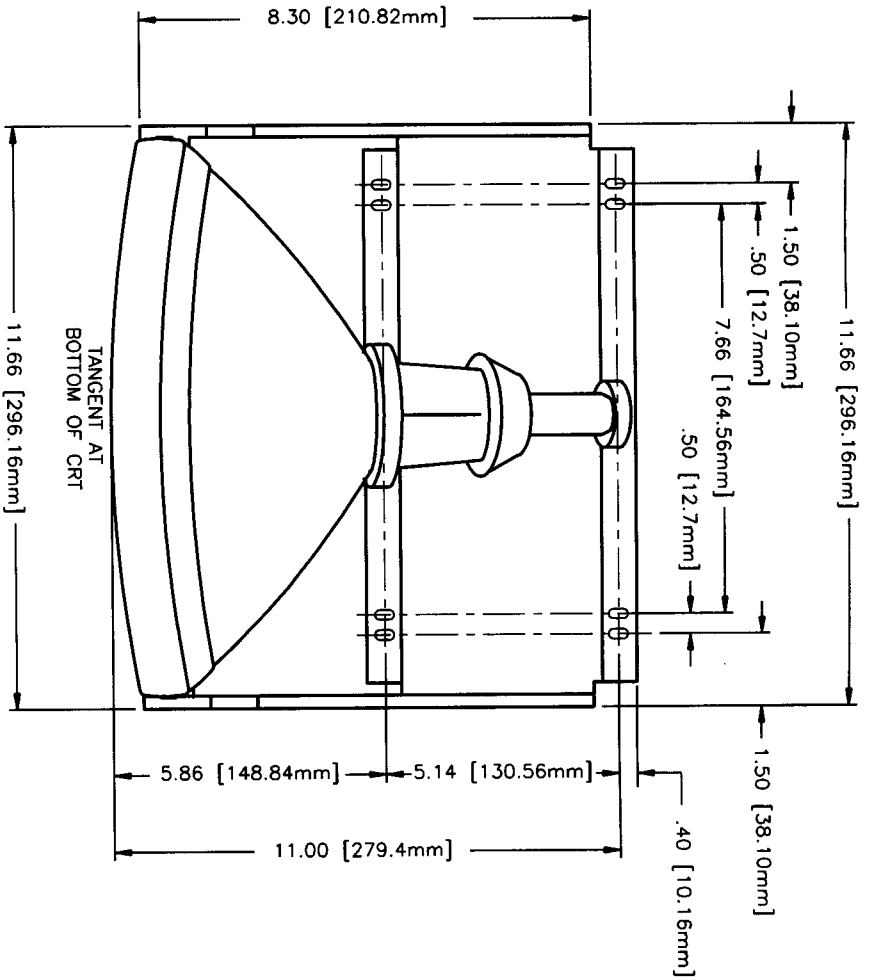

TOP VIEW

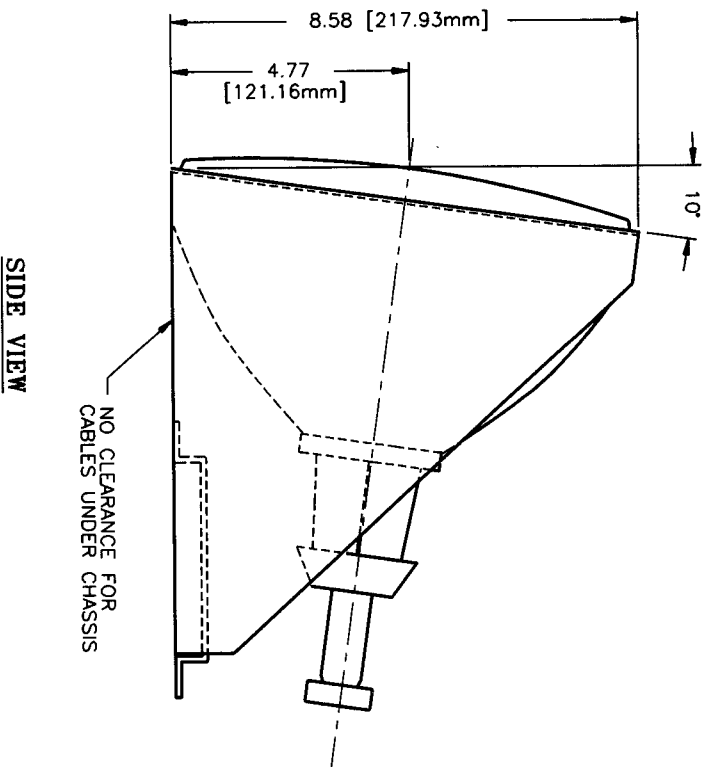

SIDE VIEW

APPROVALS		DATE		TITLE	
DRAWN: PDN		4/7/93		12" MECHANICAL DETAIL (10° TILT) STYLE "G"	
DESIGNED:				168 Brandon Dr. Glendale Heights, IL 60139	
CHECKED:				OMNI VISION INC.	
MATERIAL:		SIZE		DRWG NO.	
FINISH:		A		94-014	
		SCALE		USED ON	
		NONE		SHEET 1 OF 1	

UNLESS OTHERWISE SPECIFIED
DIMENSIONS ARE IN INCHES AND
APPLY AFTER HEAT TREAT & PLATING
TOLERANCES ON: 2 PL. DEC. ±.01
3 PL. DEC. ±.005
ANGLE: ±Z